

# Company introduction

Admatis Ltd.

Bárczy Tamás

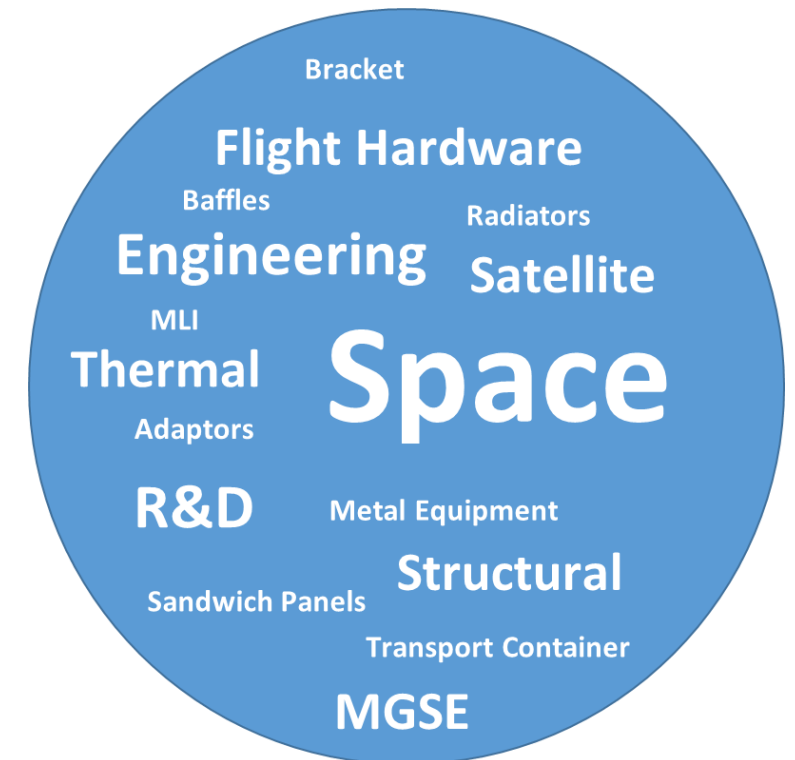

# General

- Foundation:** 2000
- Owners:** Hungarian private persons
- Location:** Miskolc, Hungary
- Size:** SME
- Position:** prime in Hungary
- Focus:** space engineering  
thermal & structural materials  
aging  
navigation support,  
MGSE
- Certificates:** AS/EN9100  
ISO9001  
CCR reg  
Ncage code  
ESA cost audit



## Motto

„Whether you believe you can do a thing or not, you’re right”  
Henry Ford

**We believe we can do it.**

# Customers / Partners

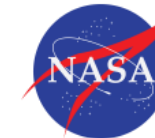

clearspace  
today



# Competencies

flight hardware  
manned missions

flight hardware  
unmanned mission

ground support  
equipments

## SPACE

**Subprime** in Hungary  
**Mechanical** and **Thermal**  
engineering  
**CAD** design  
**FEM** analysis  
ESA **documentation**  
Project and PA **management**  
Product **development**

## MATERIAL SCIENCE

**Materials R&D**  
**Aging**  
**Thermo-optical coatings**  
**Conversion coatings**  
**Multi Layer Insulation, MLI**

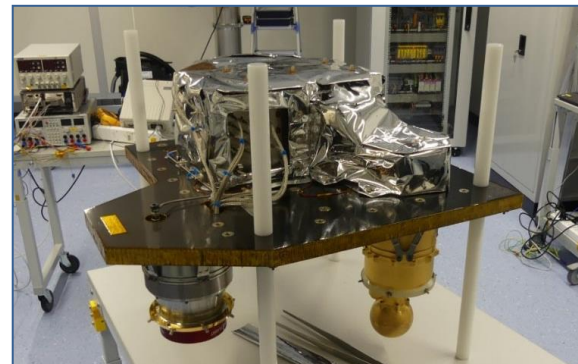
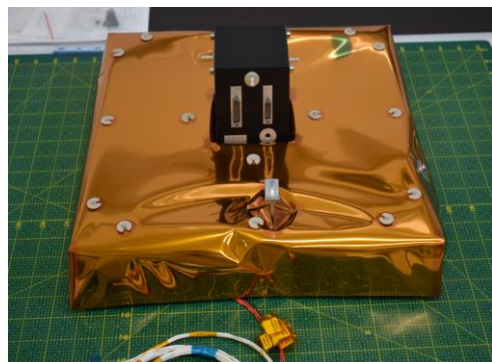
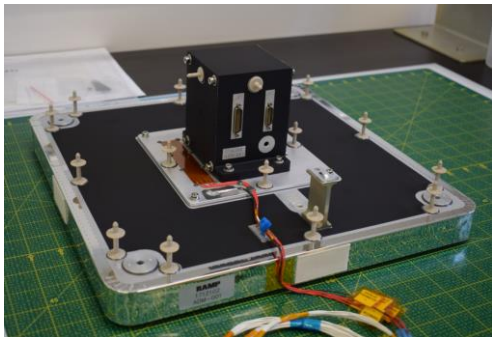
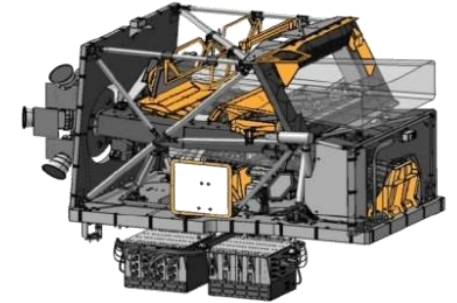

Company introduction

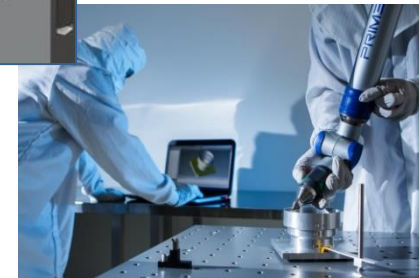
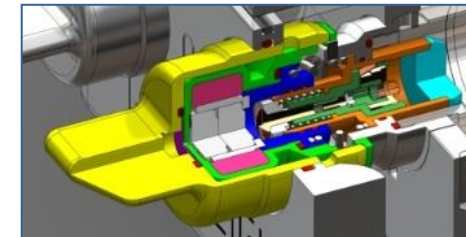

# Competencies

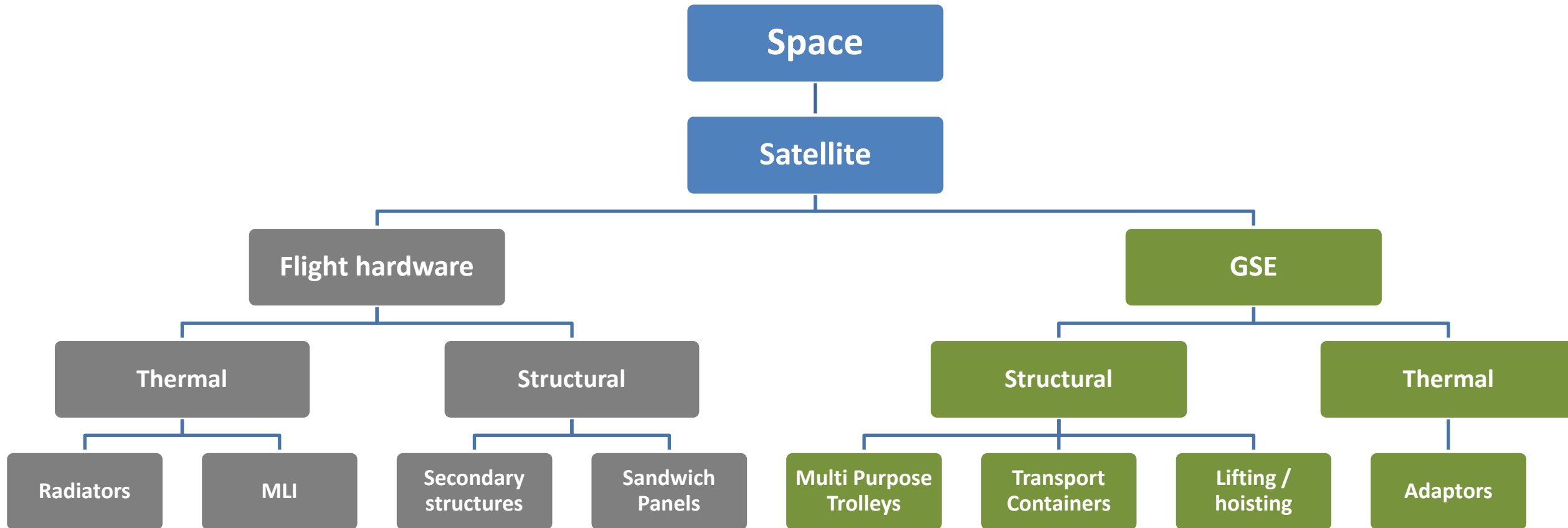

**NO IPR constraints.  
All IPRs owned by ADMATIS.**

# Engineering

- Building Requirements Specification
- CAD design (SOLIDWORKS)
- Structural and Thermal FE model (GMM and TMM) building
- FEM analysis (NASTRAN, Thermica, SOLIDWORKS Simulation)

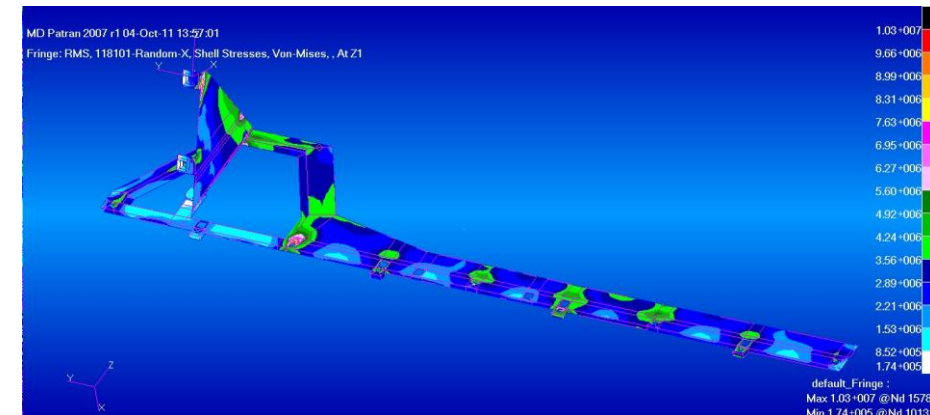
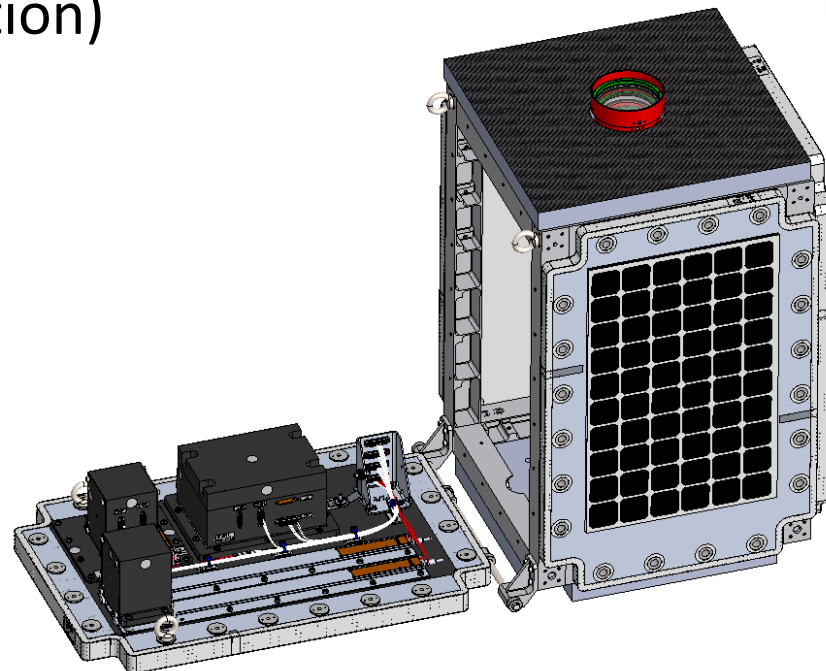
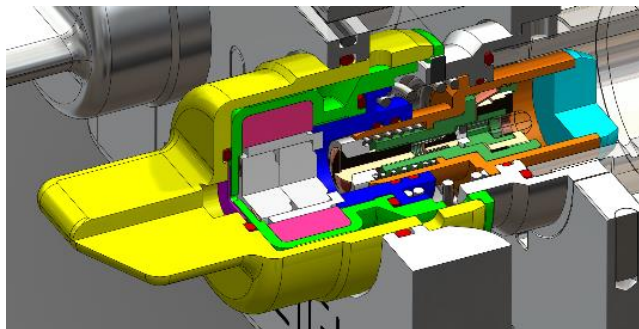
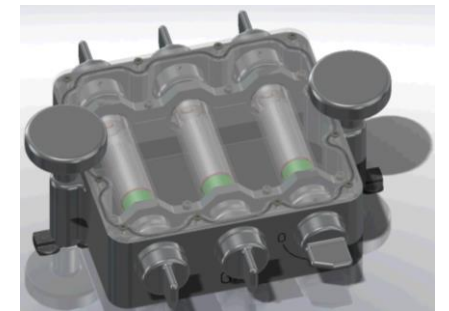
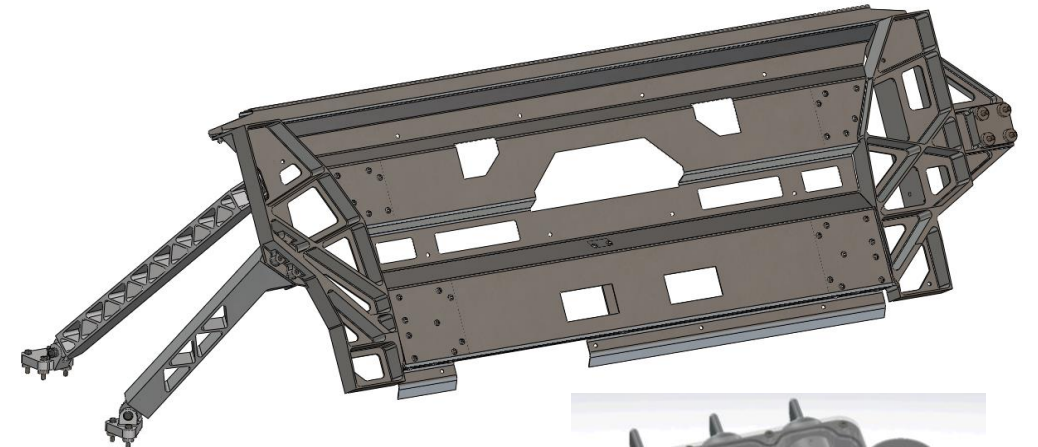

# Machining

- Internal or external suppliers
- 3, 4 and 5 axis machines
- TRL9
- Machining dimensions up to 6000x4500x1500 mm
- Tolerance up to 0.005 mm



# Surface treatment

## Conversion coatings

Types	trivalent chromium coating (SURTEC650) and hexavalent chromium coating (Alodine 1200)
Bath dimensions	950 x 500 x 180 mm
Alloys to be coated	1xxx, 2xxx, 5xxx, 6xxx and 7xxx series of aluminum alloys
Technology	manual, not automatic

## Properties

Colour	pale or dark grey
Coating weight	0.1 – 0.5 g/m <sup>2</sup>

## Qualification

Corrosion	168h / 72h NSS and 240h humidity test
Bake-out	72h, 60°C, 10 <sup>-5</sup> mbar
TVC	100 cycles ±100°C

## Compliance

Standard	ECSS-Q-ST-70-14C, prEN4729 and SP-ADST-1000112306 by Airbus
Acceptance	by ESA and Airbus

## Reference

Project	Sentinel-2 flight hardware accepted by Airbus and ESA, CHEOPS, JUICE
---------	--





# Painting

## Paint systems

Hardware size	max. 2m <sup>2</sup>
Painting booth	ISO Class 8 grade
Masking	yes
Paints	MAP PU1, MAP SG121FD, MAP PUK, Aeroglaze Z306 AQ PUK is under qualification
Primer	yes but not necessary
Technology	manual, not automatic
Overpainting	within few hours of chromating
Curing	in ISO Class 8 clean room or fast curing

## Qualification

Corrosion	240h humidity test
Bake-out	72h, 60°C, 10 <sup>-5</sup> mbar
TVC	100 cycles ±100°C
Adhesion	cross-cut and peel test

## Compliance

Acceptance	by ESA and Airbus
------------	-------------------



# MLI

**Performance:** normal & high-efficiency  
**Application:** internal and external blankets

**PROCESSES:**  
**Manufacturing:** manual or CNC cutting,  
custom perforation

**Assembly:** blanket pinning,  
blanket-to-blanket bonding by PSA,  
Velcro application by PSA,  
thermo-optical tape application

**Grounding:** grounding with Al foil and  
removable fasteners or fixed rivet

**Attachment:** standoff or Velcro

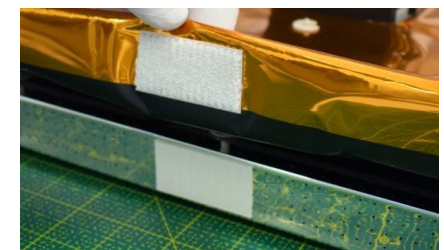
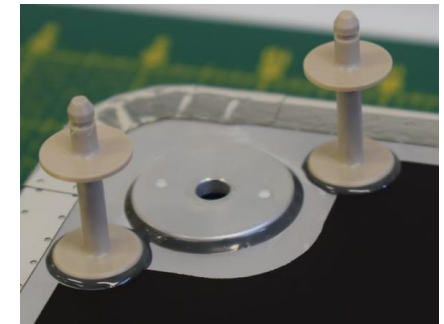

# Verification

- CMM with 1800x800mm granite table. Accuracy is ~5micron.
- Portable Measuring Arm with ~1800mm volume. Accuracy is ~27microns.
- LDS shaker 35kN with slip table and head expanders (external)
- Surface Roughness measurement
- Detailed visual inspections by optical microscope
- Cleanliness measurement by portable particle counter
- Bake-out, TVAC and thermal balance
  - internal -70°C - +100 °C
  - external AAC and ESA

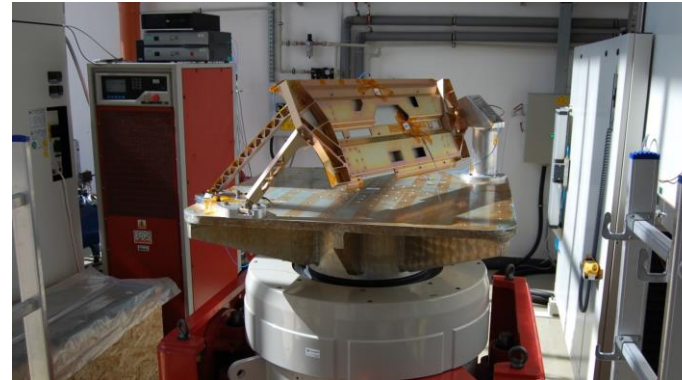
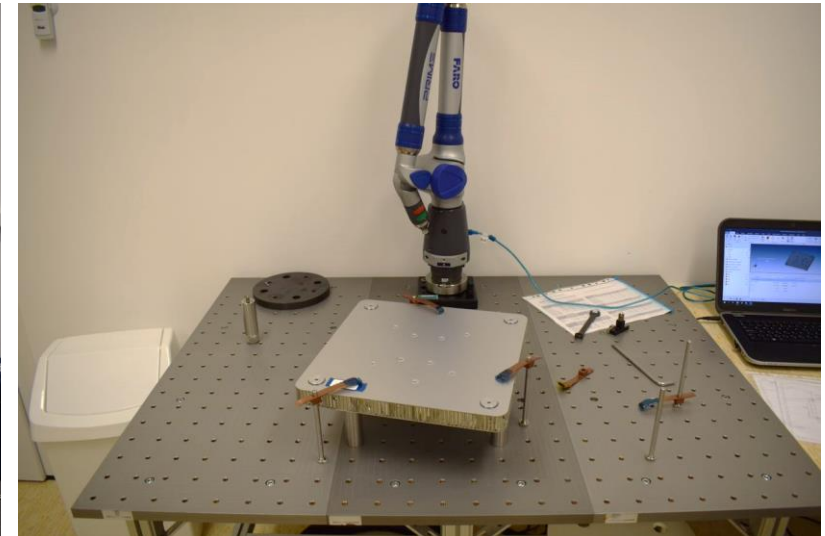

# ARIEL - Overview

## The mission:

- **Elliptical primary mirror:** 1.1 x 0.7 metres
- **Mission lifetime:** at least 4 years in orbit
- **Payload mass / launch mass:** ~500 kg / ~ 1500kg
- **Instrumentation:** 3 photometric channels and 3 spectrometers covering continuously from 0.5 to 7.8 microns in wavelength
- **Launch date:** 2029
- **Destination:** Sun – Earth Lagrange Point 2 (L2)
- **Launch vehicle:** Ariane 6-2. Launch shared with Comet Interceptor.

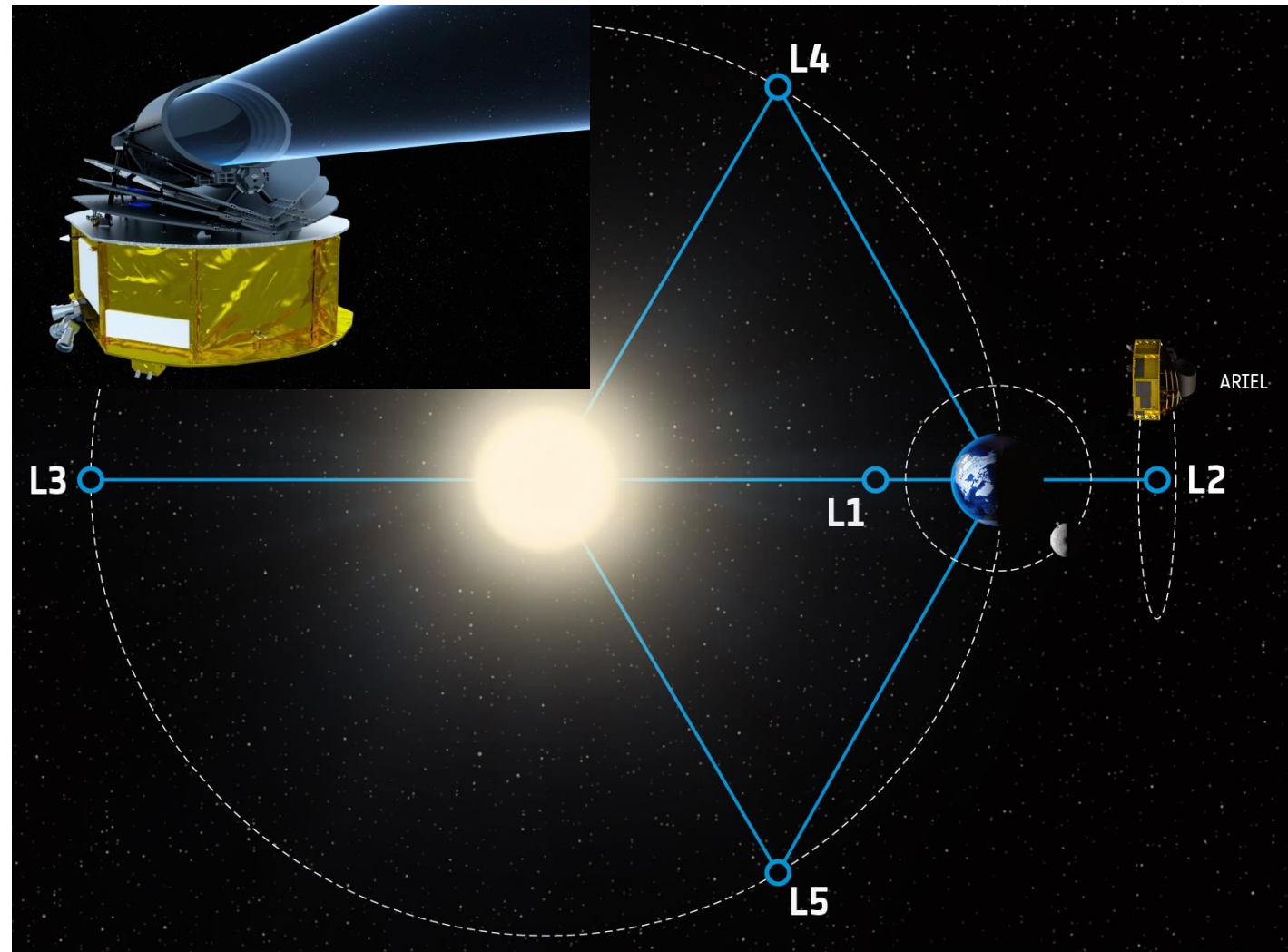

# ARIEL - Overview

## The Team:

- Ariel mission consortium is led by RAL space UK.
- Prime contractor is ADS
- Contributions from 22 ESA states and NASA and JAXA.

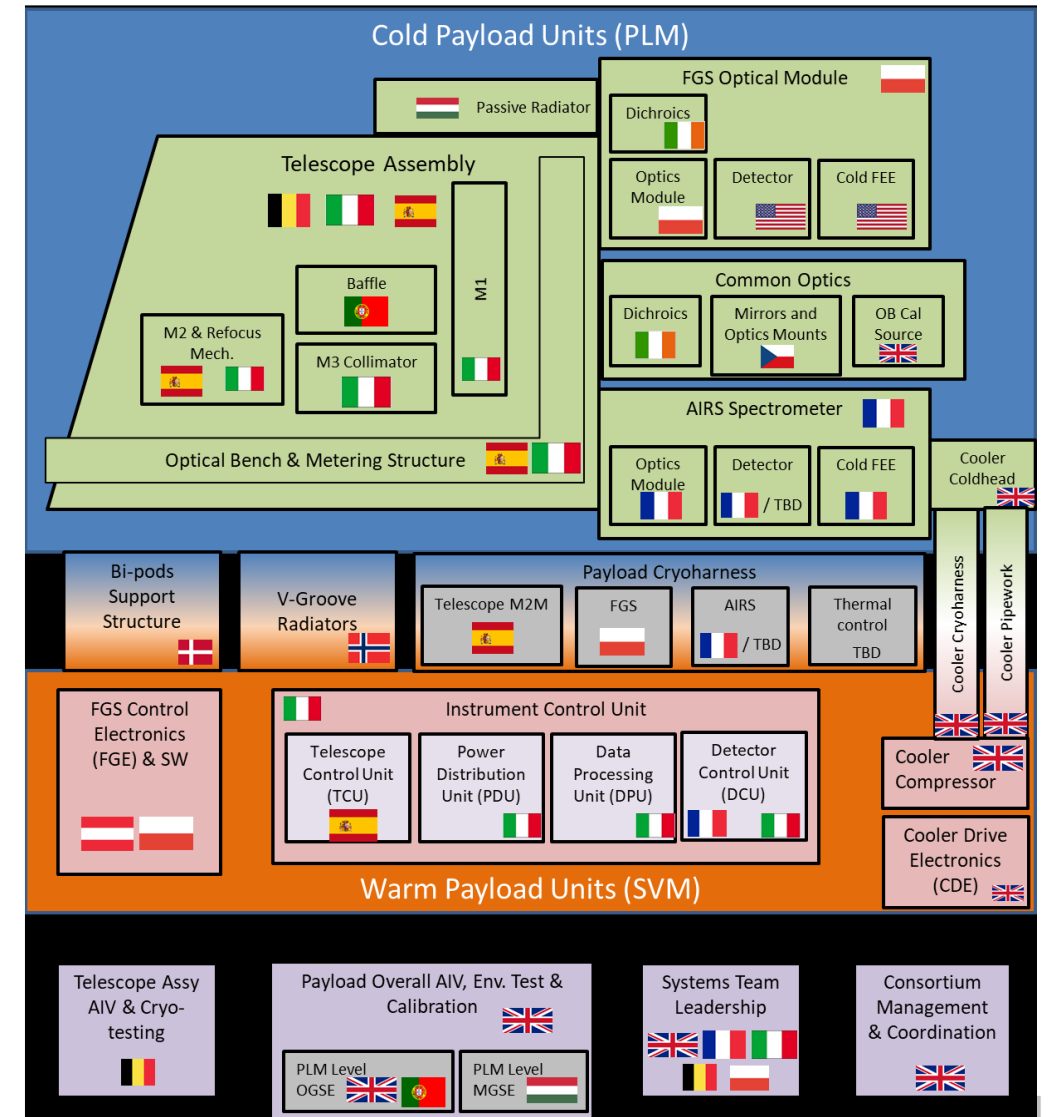

# ARIEL - Payload

## Purpose of Instrument Radiator:

- Instrument Cooling
- Radiation Shielding
- (TOB assembly stiffening)

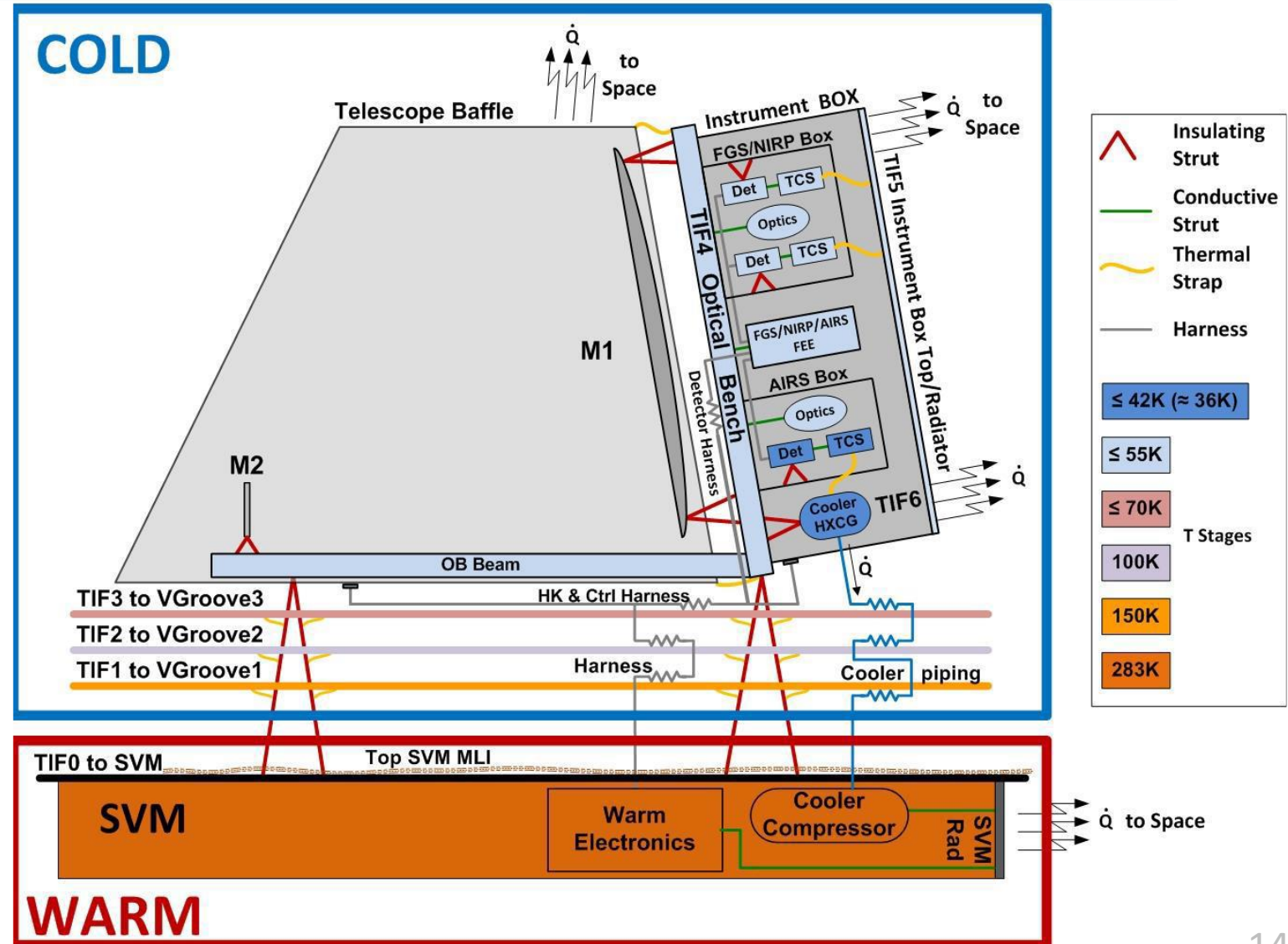
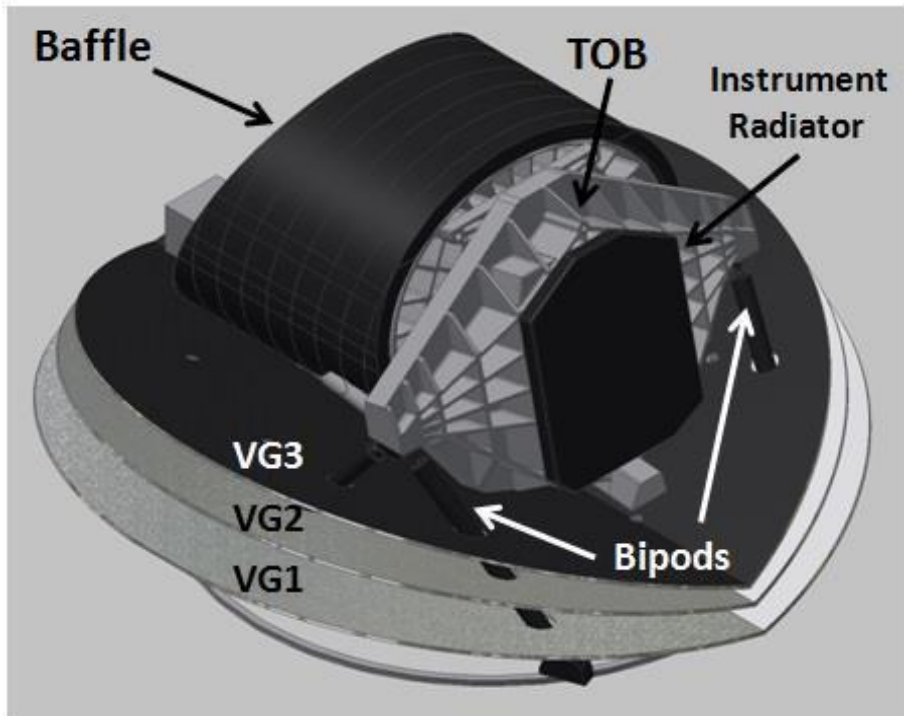

# ARIEL – Flight hardware

## Instrument Radiator Subsystem

- Light tightly seals instrument cavity while ensuring the necessary radiative cooling capacity to dissipate heat produced by instruments into deep space.
- Challenging due to cryogenic (45K) operation temperature.
- Equipped with monitoring thermal sensors.
- Features special honeycomb radiative interface to compensate coating's low emittance at cryo.
- Build-to-spec

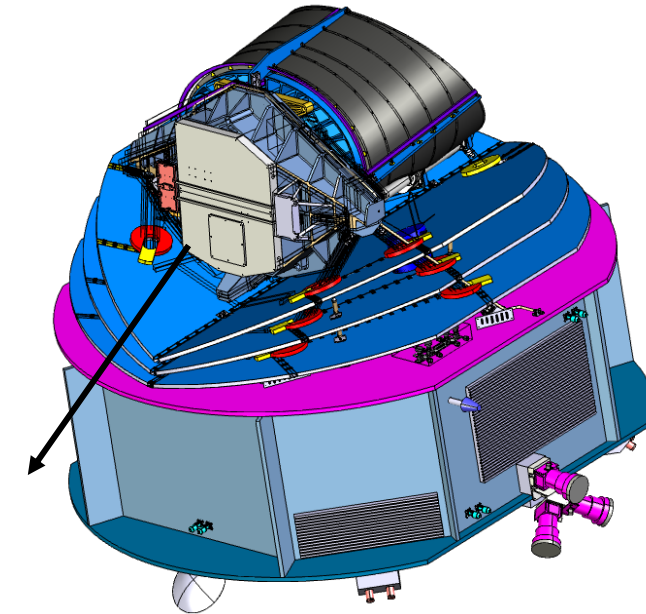
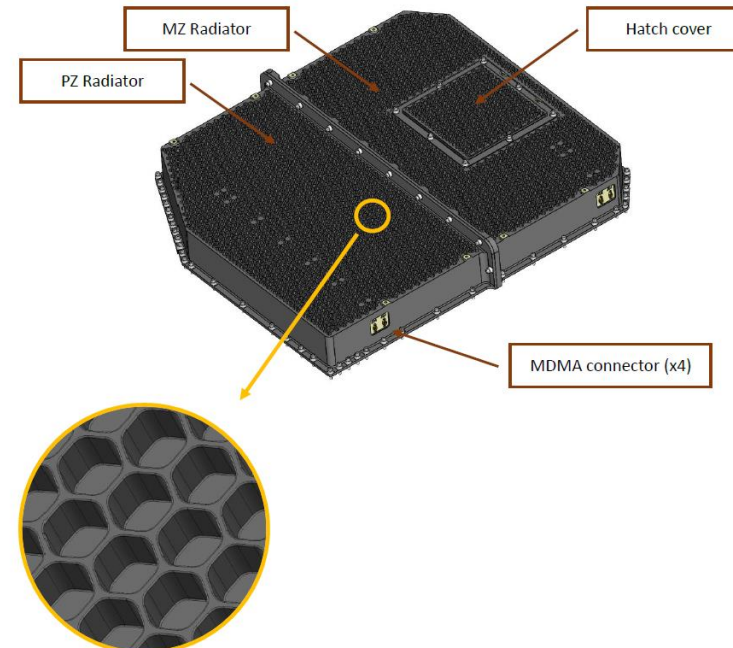

# ARIEL – MGSE

Payload Lifting Frame (PLF)

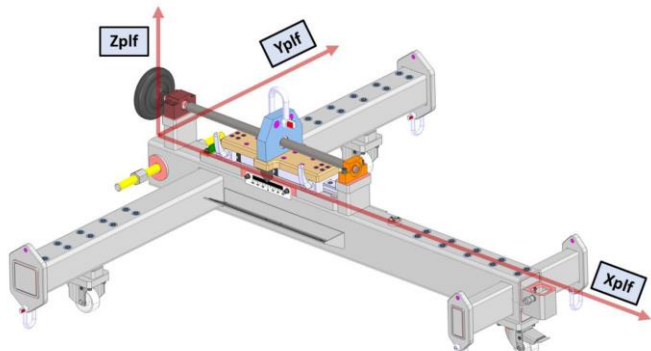

Telescope Lifting Adaptor (TLA)



Telescope Rotation Jig (TRJ)

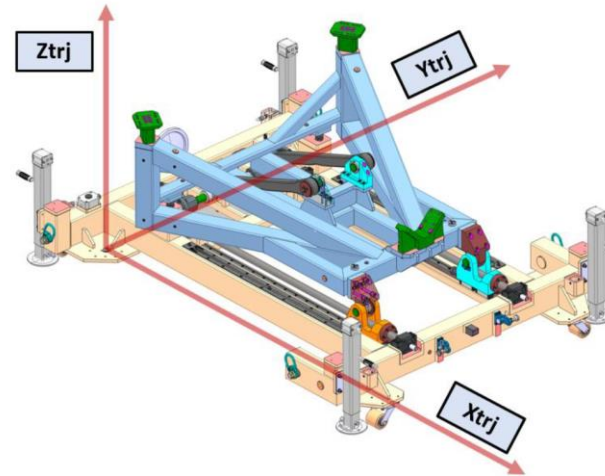

Universal Lifting Beam (ULB)  
Container Lifting Beam (CLB)

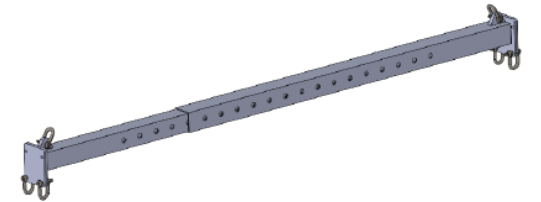

Payload Transport Container (PTC)

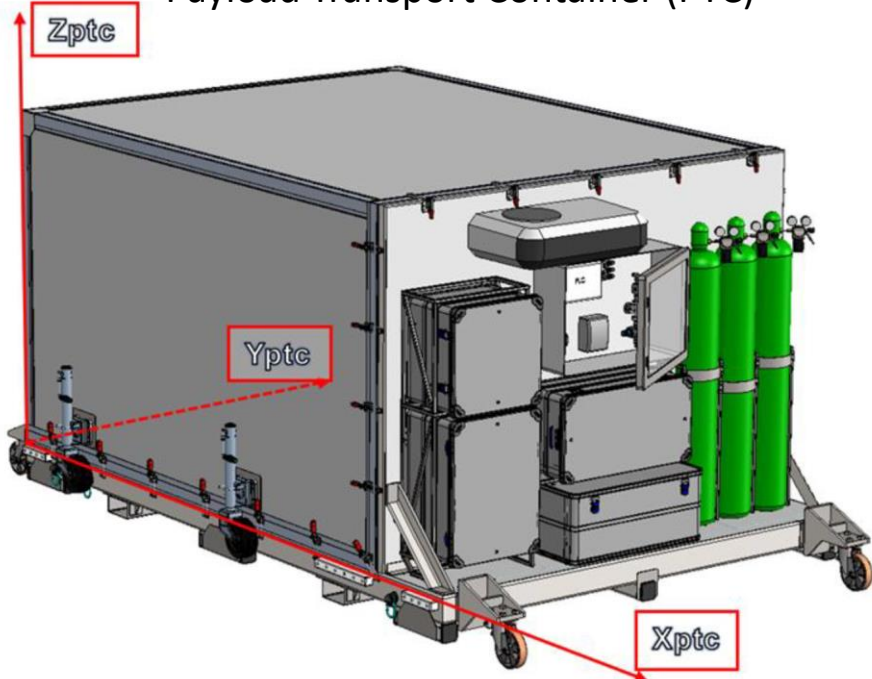

GSE Transport Container (GTC)



Multi-Purpose Trolley (MPT)

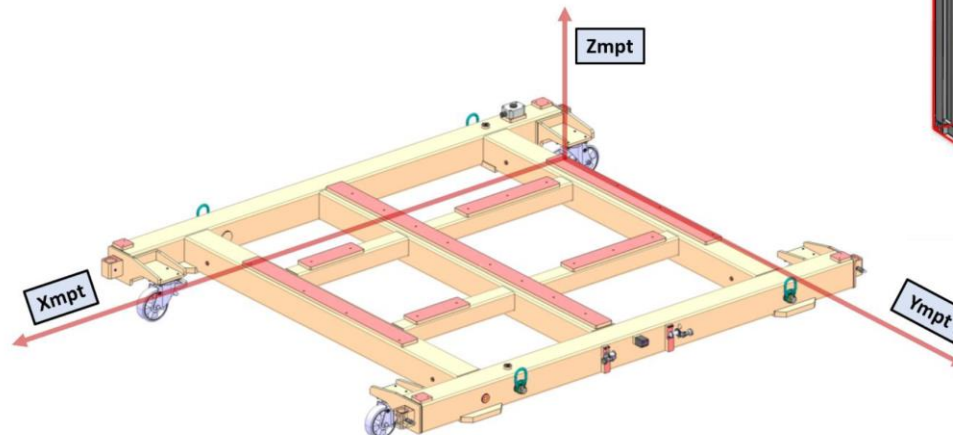



# ARIEL – MGSE

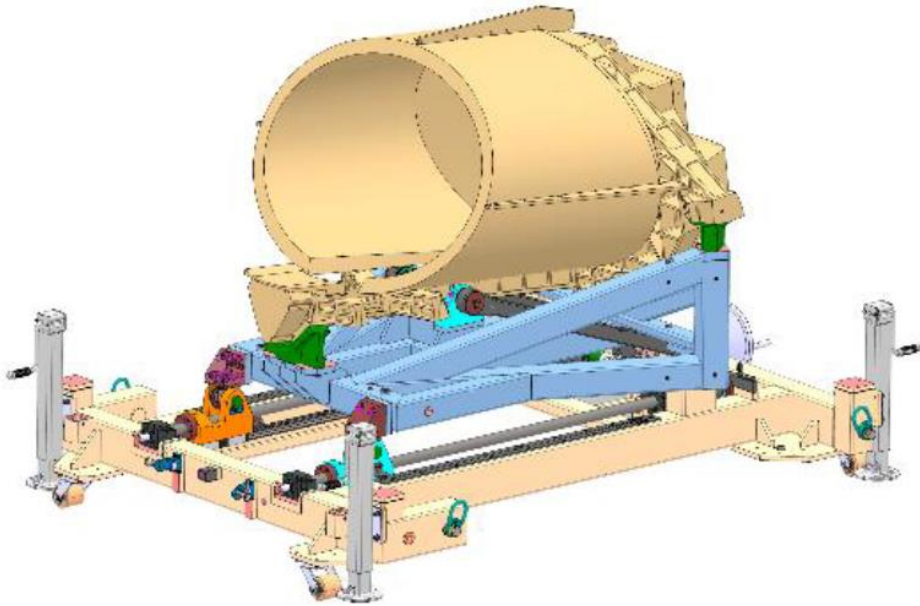

54. Figure – TRJ with TA

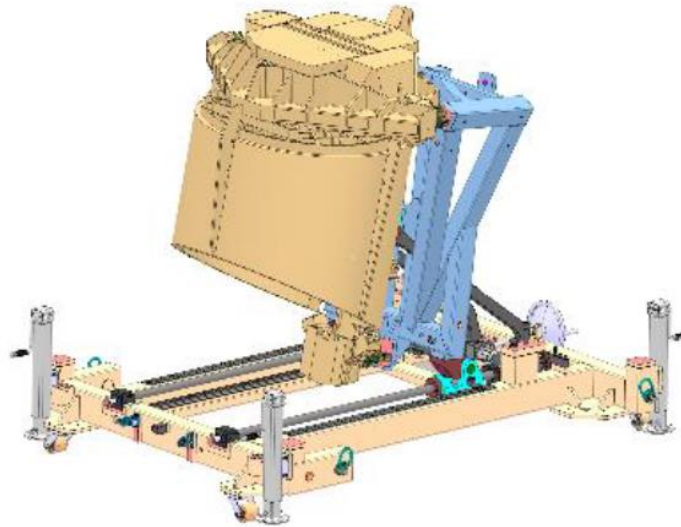

55. Figure – TRJ in integration position

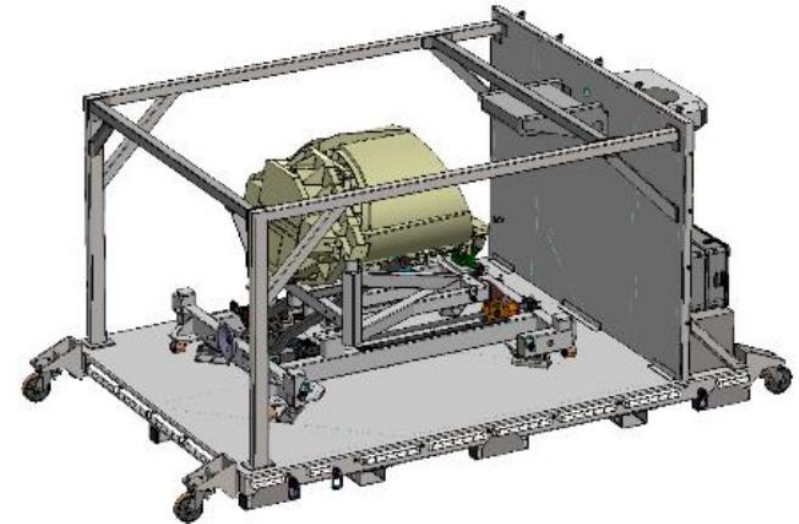

TRJ and TA in the PTC

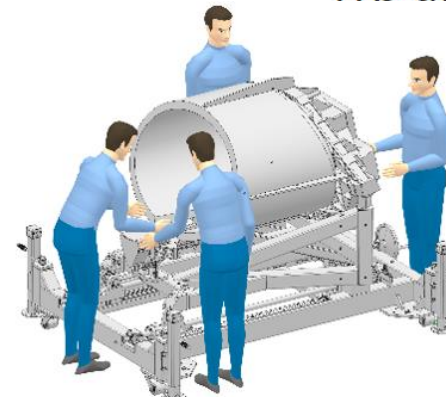

# CO2M – Thermal Guard Assembly

Copernicus is one of the largest European space program for Earth Observation.

CO2M is part of ESA HPCM (High Priority Candidate Missions) / Copernicus Expansion Mission.

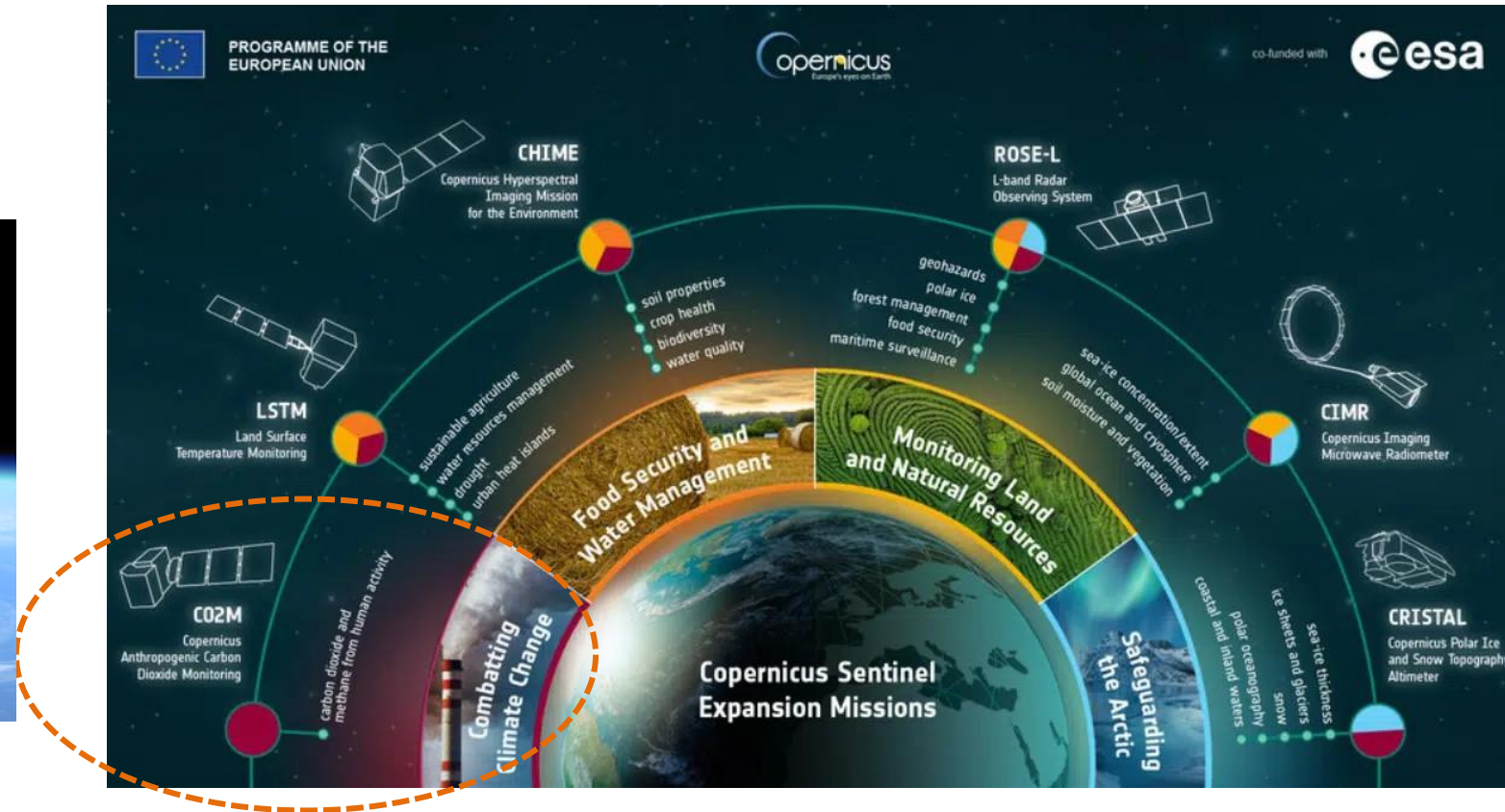
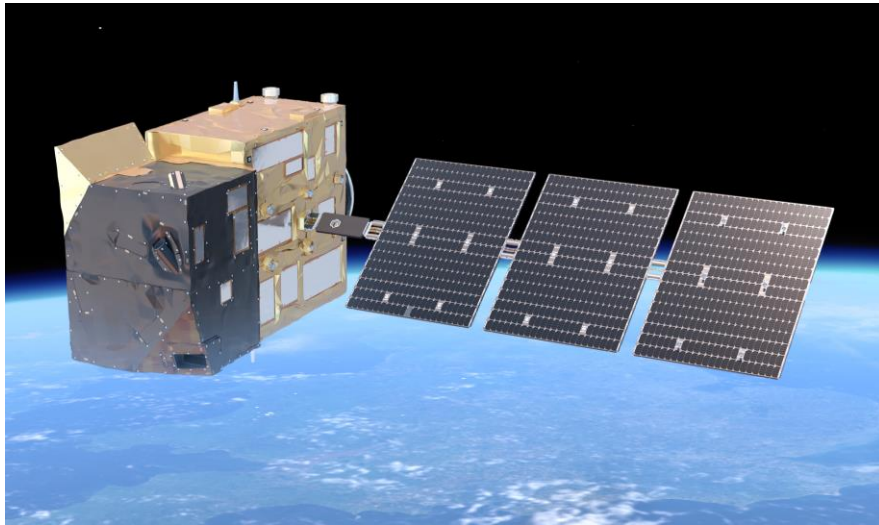

Mission is the climate change monitoring.

The aim of the CO2M mission is the detection and measurement of climate damaging gas focusing on carbon-dioxide and nitrogen-dioxide.

# CO2M – Flight hardware

---

- Selection in open competition
- Encapsulation and thermal insulation of CO2 spectrometer.
- Design, analysis, manufacturing and testing of PFM, FM2 and FM3 (TBC)
- Platform provider: Thales Alenia Space France / Prime: OHB
- Build-to-spec

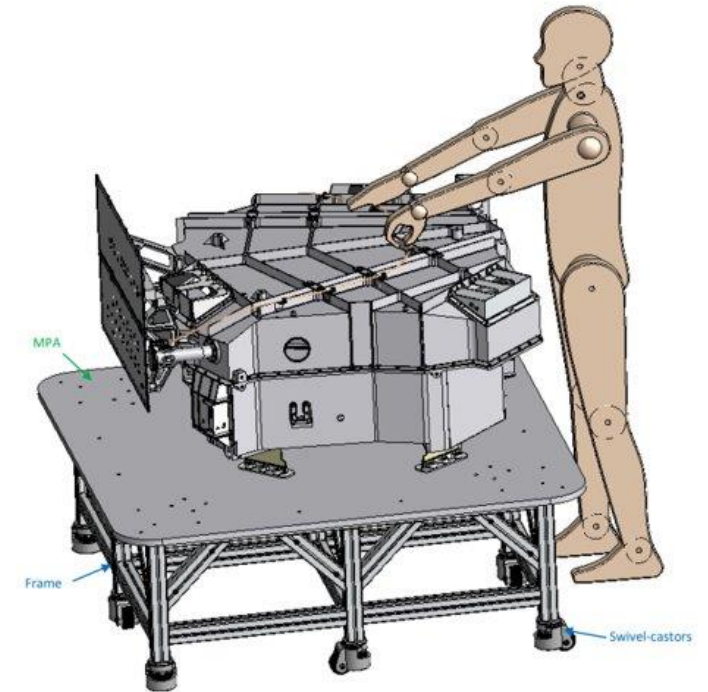

# CO2M – Flight hardware

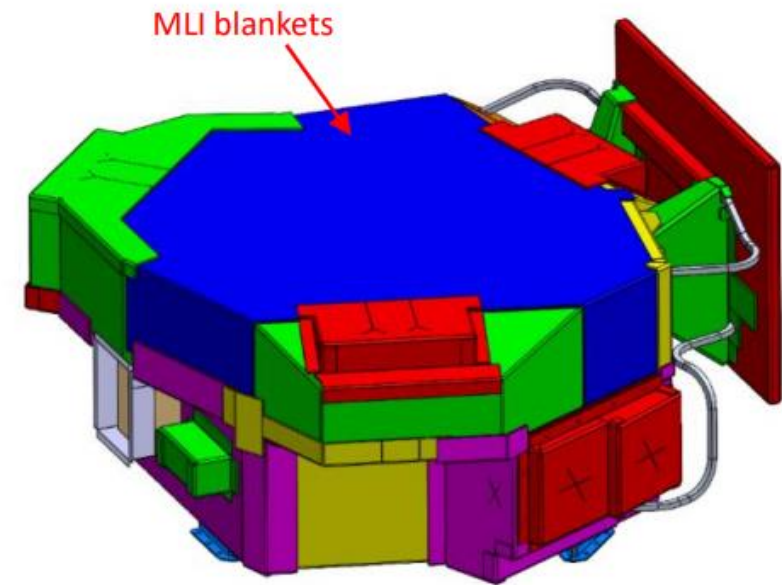
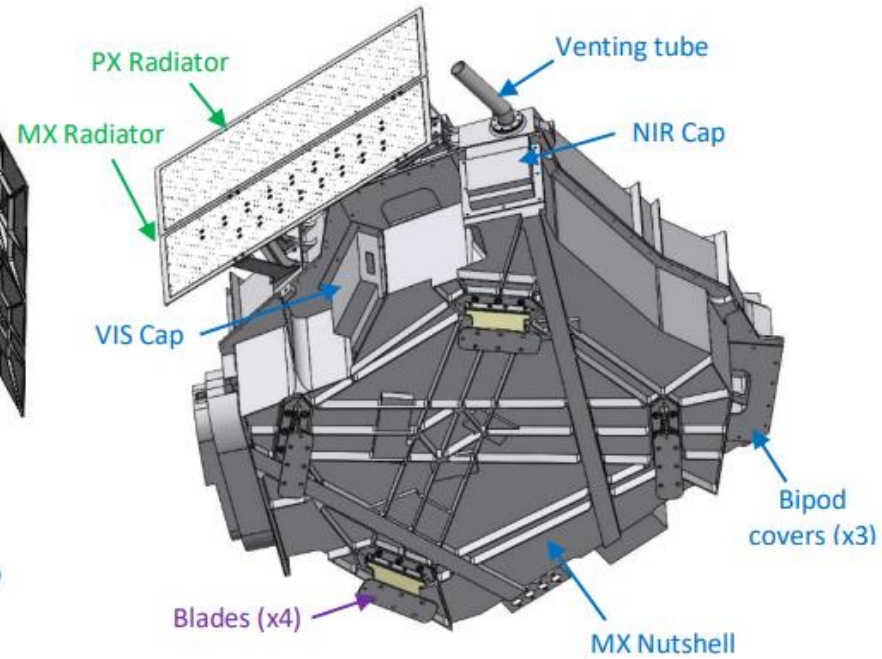
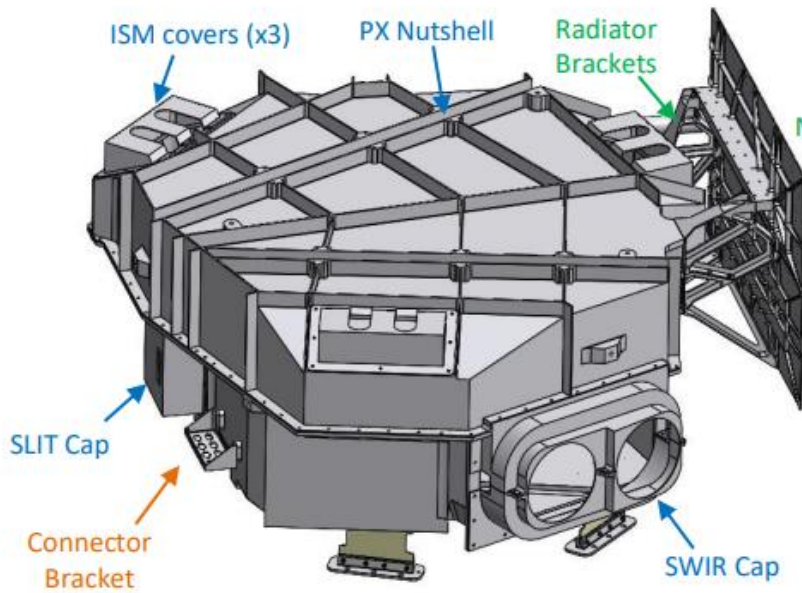

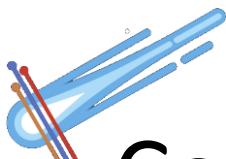

# Comet Interceptor – Flight hardware

## MISSION PROFILE

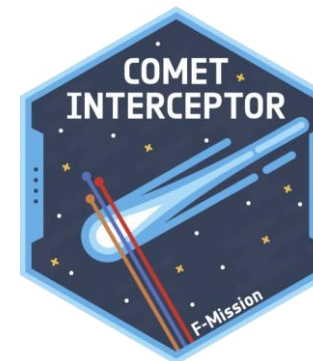
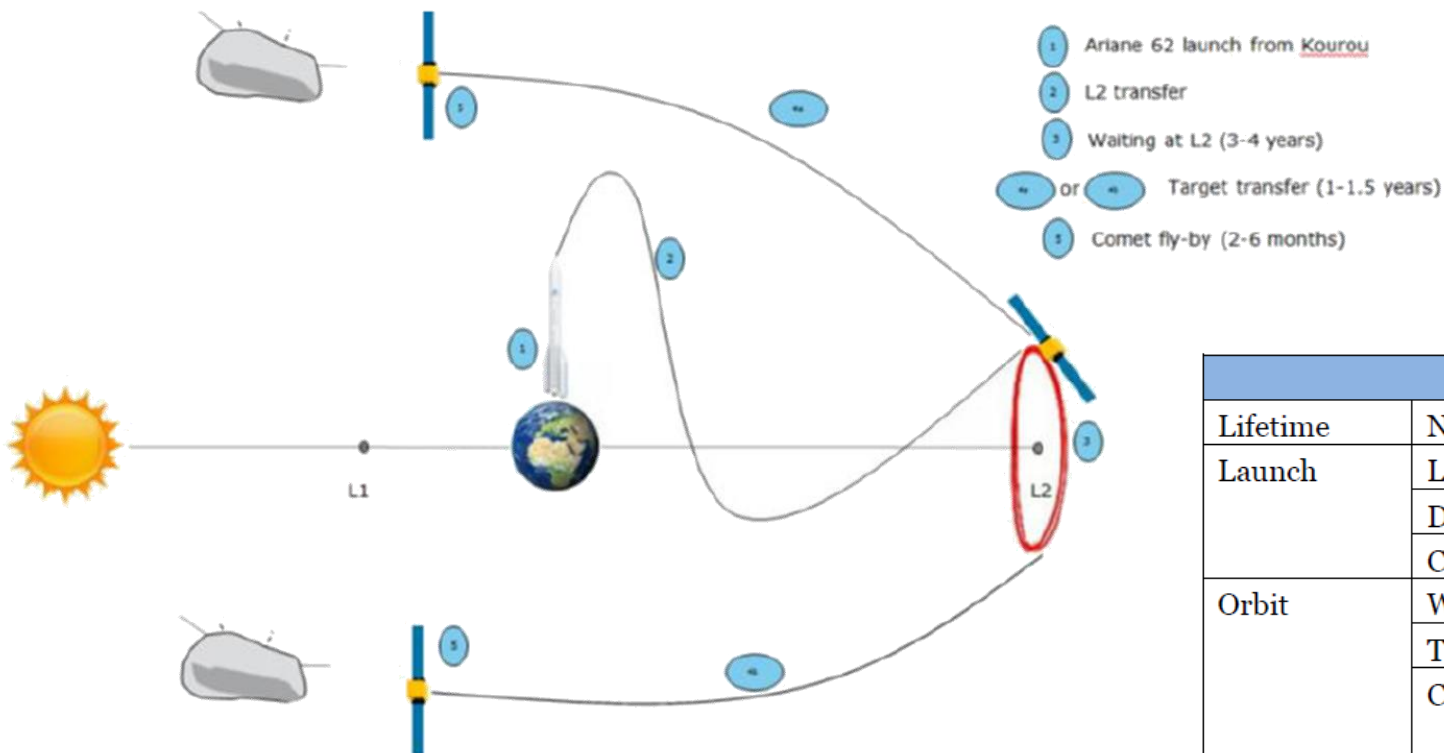

The mission's primary science goal is to characterize, for the first time, a dynamically-new comet or interstellar object, including its surface composition, shape, and structure, the composition of its gas coma.

Prime: OHB Italy

CoCa leader: University of Bern

Comet Interceptor – Mission summary		
Lifetime	Nominal 5 years with maximum 6 months of Science Operations	
Launch	Launcher	Ariane 6.2
	Date	2028
	Configuration	Shared, dual launch with ARIEL mission
Orbit	Waiting phase	Halo orbit around SEL2 point
	Target transfer phase	Heliocentric trajectory close to Earth orbit
	Conditions at encounter	Heliocentric distances between 0.9 and 1.25 AU Solar phase angle range at encounter +/-45 deg Fly-by relative velocity at encounter $\leq 70$ km/s
Overall system characteristics		
Mass	Dry mass	655 kg
	Wet mass	796 kg (incl. probes B1 and B2)
Dimensions	Stowed	1,974 mm x 2,073 mm x 1,976 mm
	Deployed	9,768 mm x 2,999 mm x 2,484 mm
Delta-V	Chemical propulsion	110 m/s
	Electric propulsion	1522.5 m/s

# Comet Interceptor – Flight hardware

- ESA Project
- Objective is to develop passive and active thermal control hardware for Comet Interceptor’s instrument called COmet Camera (CoCa).
- Active and Passive Thermal Control packages are under ADMATIS responsibilities.
- Build-to-spec

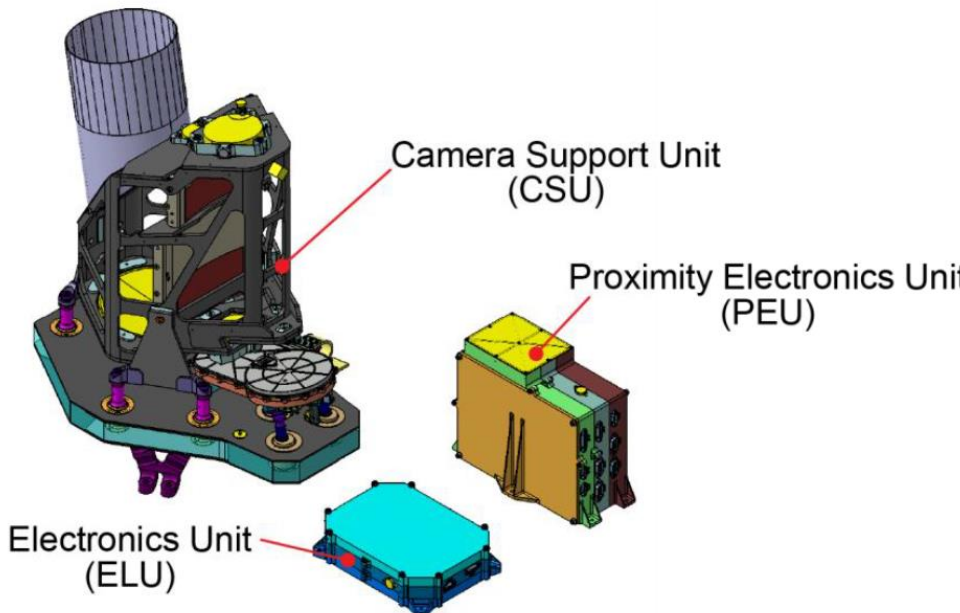
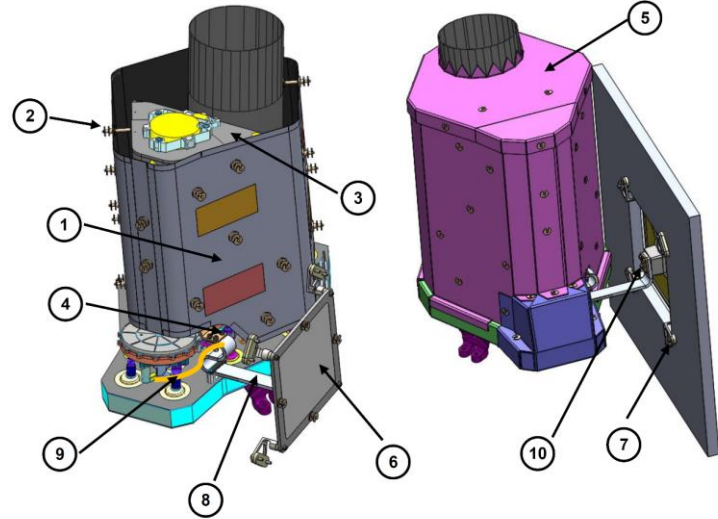
COCA OVERVIEW	ADMATIS HARDWARE																								
 <p>Camera Support Unit (CSU)</p> <p>Proximity Electronics Unit (PEU)</p> <p>Electronics Unit (ELU)</p>	 <table border="1" data-bbox="1337 1213 2140 1335"> <thead> <tr> <th>ID</th> <th>Description</th> <th>ID</th> <th>Description</th> </tr> </thead> <tbody> <tr> <td>1</td> <td>Survival Heater Module (SHM)</td> <td>6</td> <td>FPA radiator</td> </tr> <tr> <td>2</td> <td>SHM and MLI fixations</td> <td>7</td> <td>FPA radiator fixations</td> </tr> <tr> <td>3</td> <td>Telescope survival sensors</td> <td>8</td> <td>FPA Thermal strap</td> </tr> <tr> <td>4</td> <td>FPA survival heater and sensors</td> <td>9</td> <td>FWM thermal strap</td> </tr> <tr> <td>5</td> <td>CSU Multi-layer Insulation</td> <td>10</td> <td>Thermal strap fixations</td> </tr> </tbody> </table>	ID	Description	ID	Description	1	Survival Heater Module (SHM)	6	FPA radiator	2	SHM and MLI fixations	7	FPA radiator fixations	3	Telescope survival sensors	8	FPA Thermal strap	4	FPA survival heater and sensors	9	FWM thermal strap	5	CSU Multi-layer Insulation	10	Thermal strap fixations
ID	Description	ID	Description																						
1	Survival Heater Module (SHM)	6	FPA radiator																						
2	SHM and MLI fixations	7	FPA radiator fixations																						
3	Telescope survival sensors	8	FPA Thermal strap																						
4	FPA survival heater and sensors	9	FWM thermal strap																						
5	CSU Multi-layer Insulation	10	Thermal strap fixations																						

# Comet Interceptor – Flight hardware

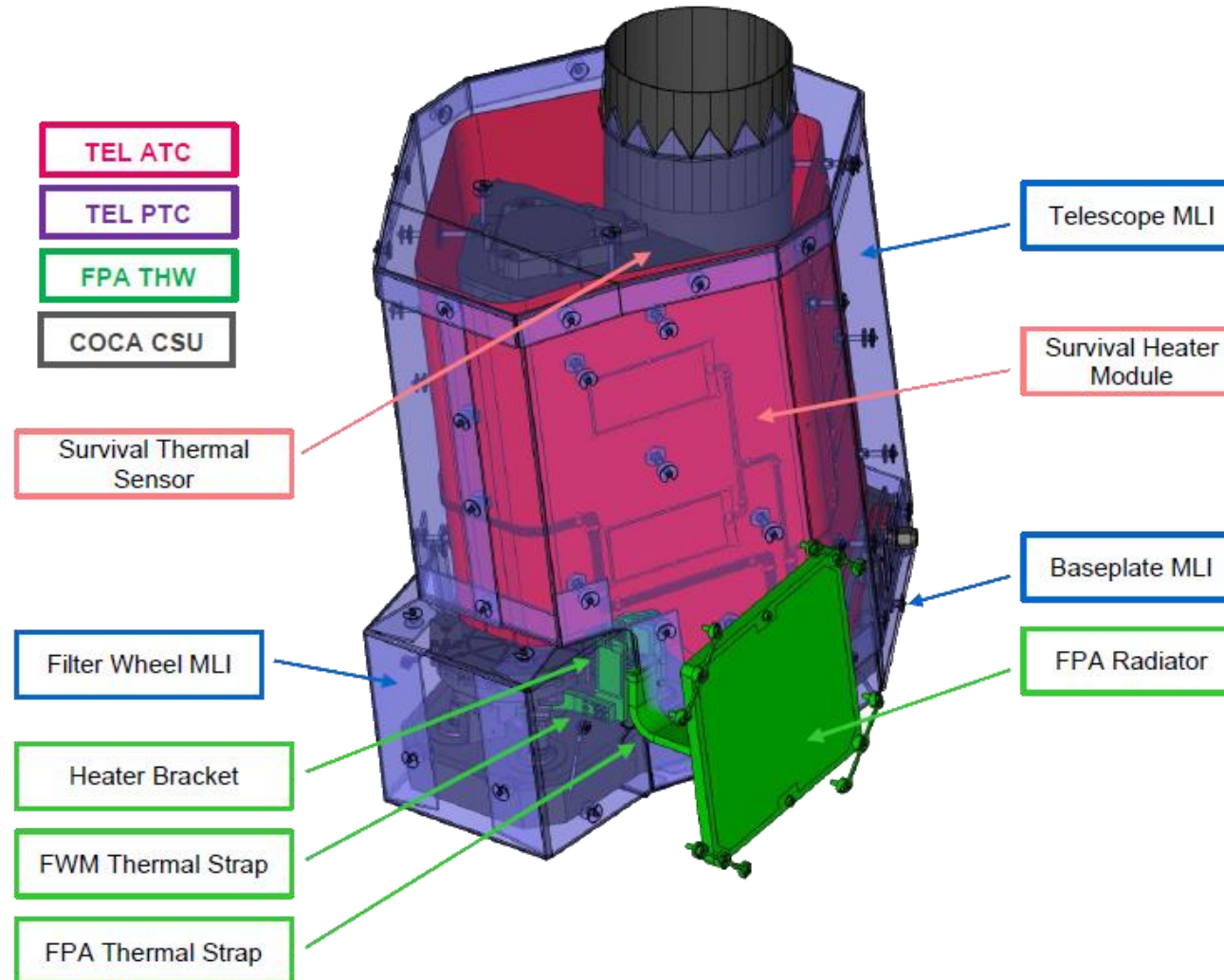

# MSR – ERO – SDS – The Mission

- External scientific instrument for radiation measurement
- Prime: Airbus
- Build-to-spec
- 2022 – 2025
- Hungarian team: EK, ADMATIS, Remred
- ADMATIS is responsible for thermal and structural subsystems

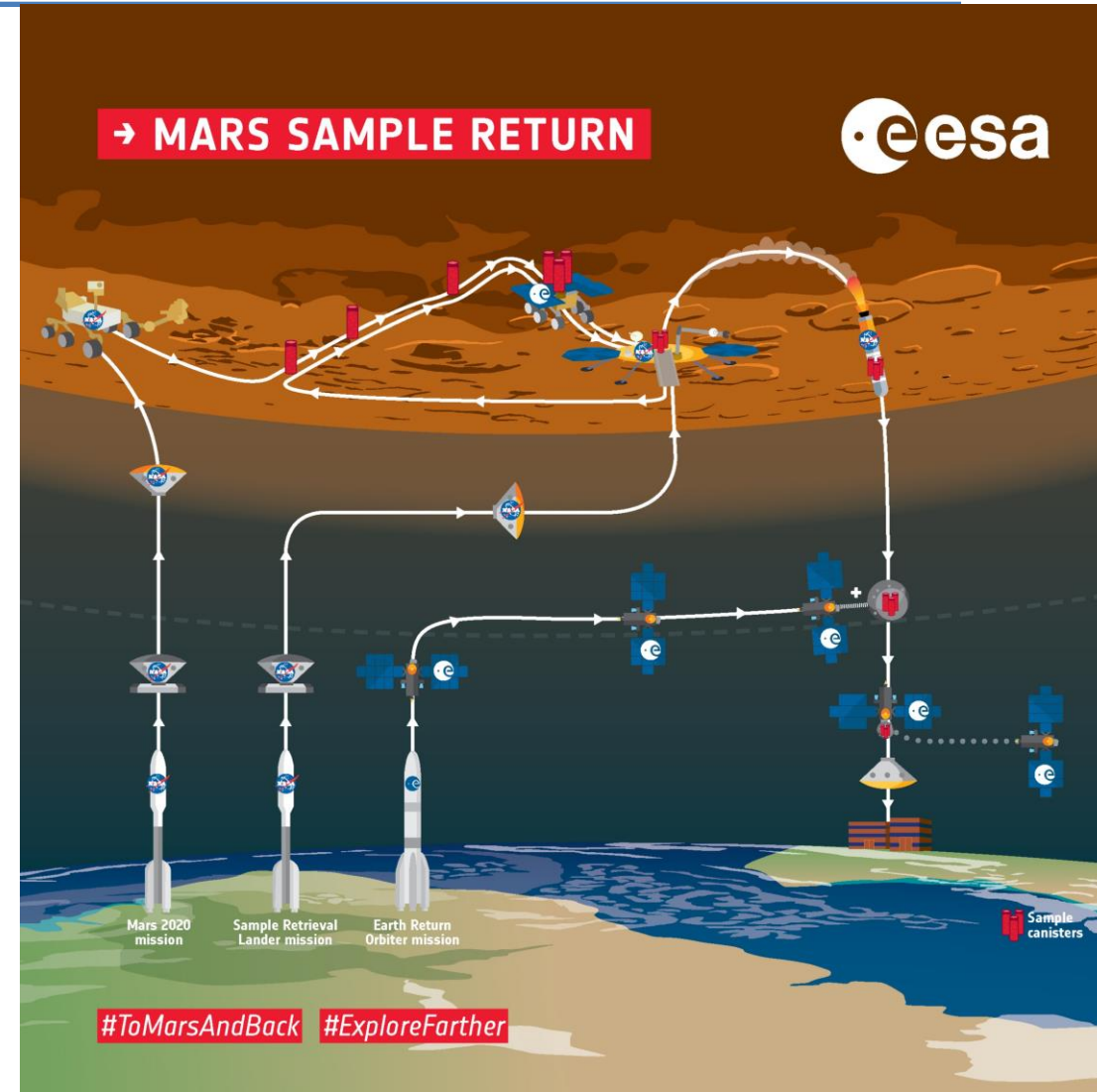



# MSR – ERO – SDS – Spacecraft

## EARTH RETURN ORBITER Martian size matters

Earth Return Orbiter will be the **biggest spacecraft** to ever orbit Mars

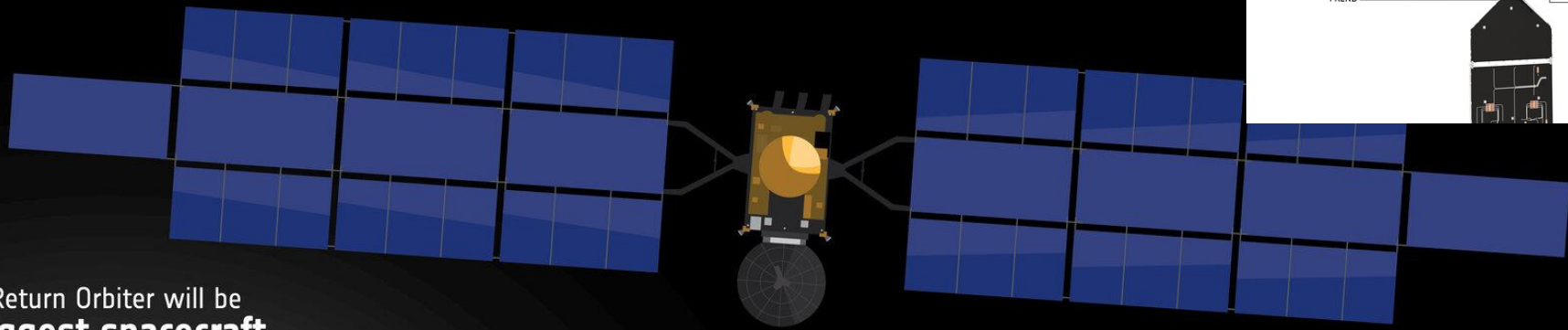
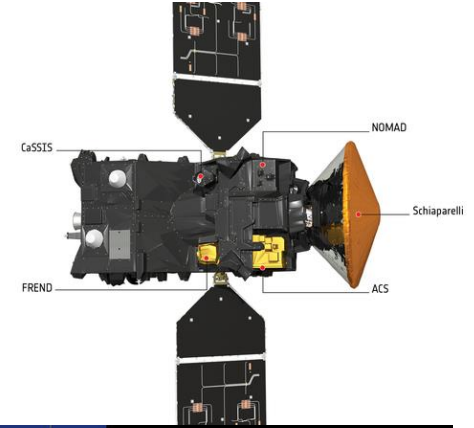

**Mars Reconnaissance Orbiter** 

Wingspan: 13.6 m  
Height: 6.5 m



**Trace Gas Orbiter** 

Wingspan: 17.5 m  
Height: 3 m

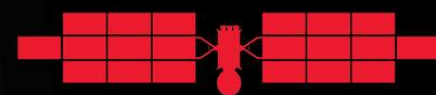

**Earth Return Orbiter** 

Wingspan: 38 m  
Height: 7.5 m

# MSR – ERO – SDS – Flight hardware

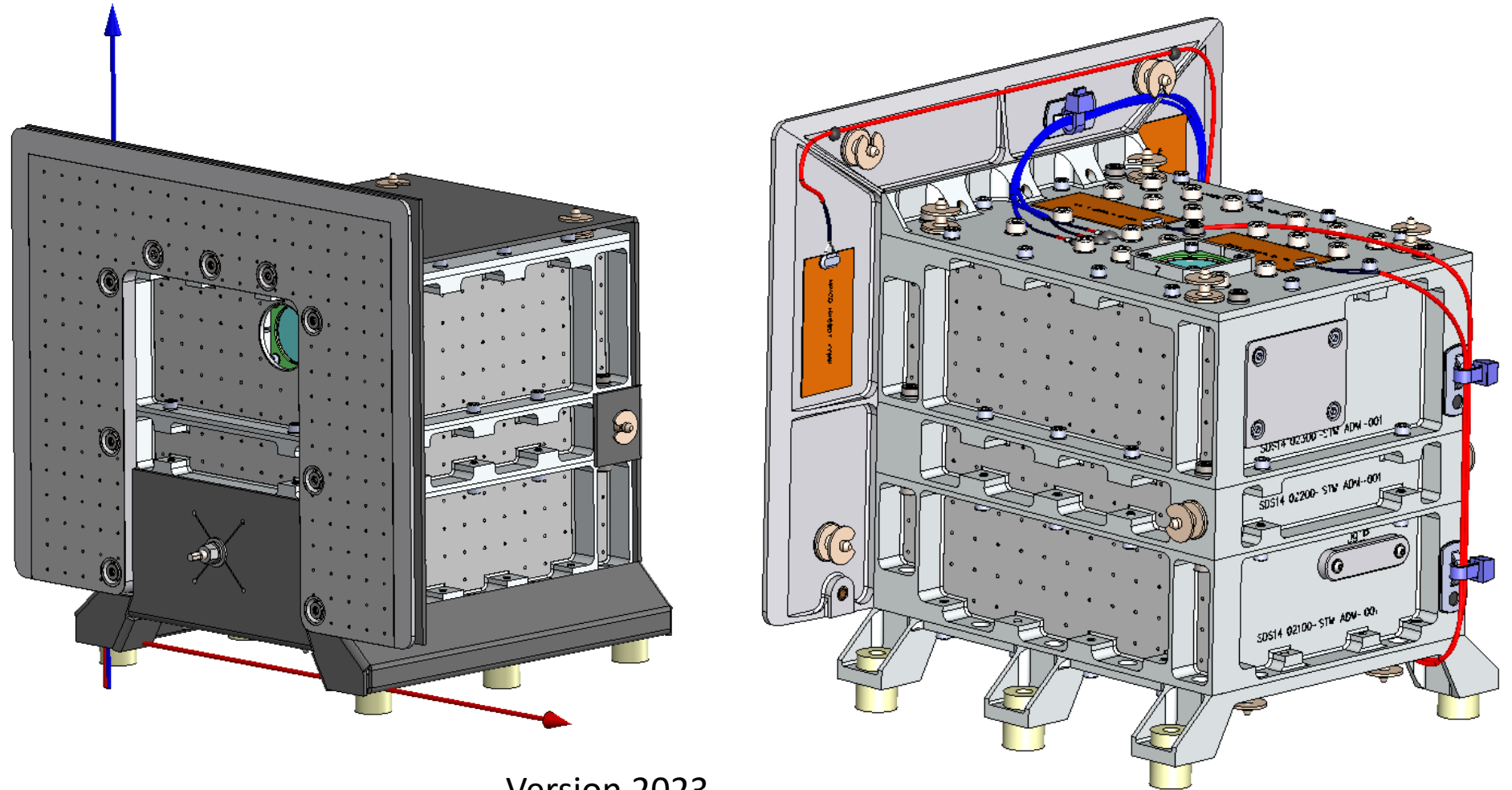

Version 2023

# Mission Overview - MSN

## ESA CLEANSPACE

CLEAN SPACE IS THE EUROPEAN SPACE AGENCY'S INITIATIVE, STARTED IN 2009 WITH THE ECOSAT STUDY, TO SAFEGUARD THE TERRESTRIAL AND ORBITAL ENVIRONMENTS, WHILE BOOSTING THE INNOVATION AND COMPETITIVENESS OF EUROPE'S SPACE SECTOR.

## CLEAN SPACE HAS THREE BRANCHES:

They reflect its mission to assess the environmental impacts of Agency programmes designed to find ways to address these challenges and contribute to a more sustainable and competitive European space industry.

- **ECODESIGN:** Embedding environmental sustainability within space mission design.
- **MANAGEMENT OF END OF LIFE:** Developing technologies to prevent the creation of future debris.
- **IN-ORBIT SERVICING:** Actively removing spacecraft from orbit and demonstrating in-orbit servicing.



# Markers Supporting Navigation

ESA R&D project portfolio with 5 projects at ADMATIS.

The first was competitive with other possible solutions.

Objectives:

- develop something than can be detected after 15 years LEO conditions with visible and thermal infrared cameras
- BOL and EOL properties are almost the same
- support navigation with range 40 – 0 meter
- detectable from Earth by laser technology

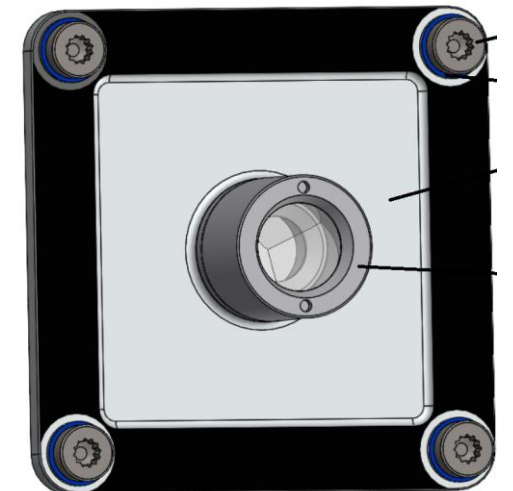
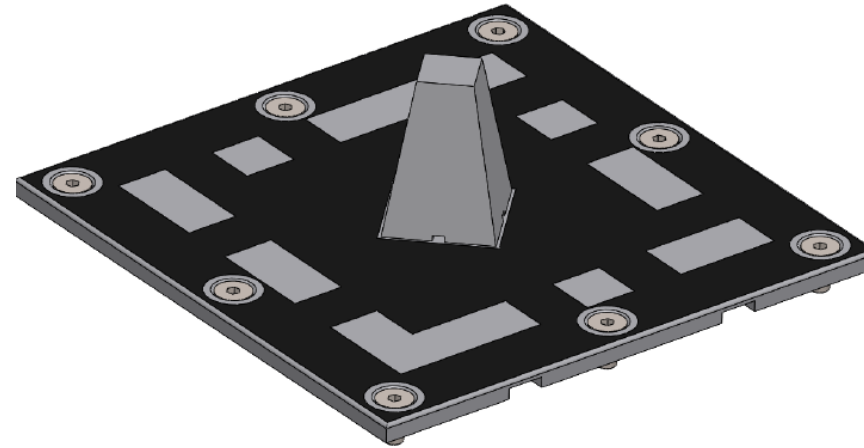

# Markers Supporting Navigation

ESA – ADMATIS exclusive supplier contract signed in 2023.

The first industrial orders received:

- ESA AVS (AVS)
- ESA HPCM CRISTAL (Airbus)
- ESA HPCM LSTM (Airbus)

New developments running:

- phosphorescent painted Markers
- GNC test facility
- Markers for constellations
- System level leader of international team

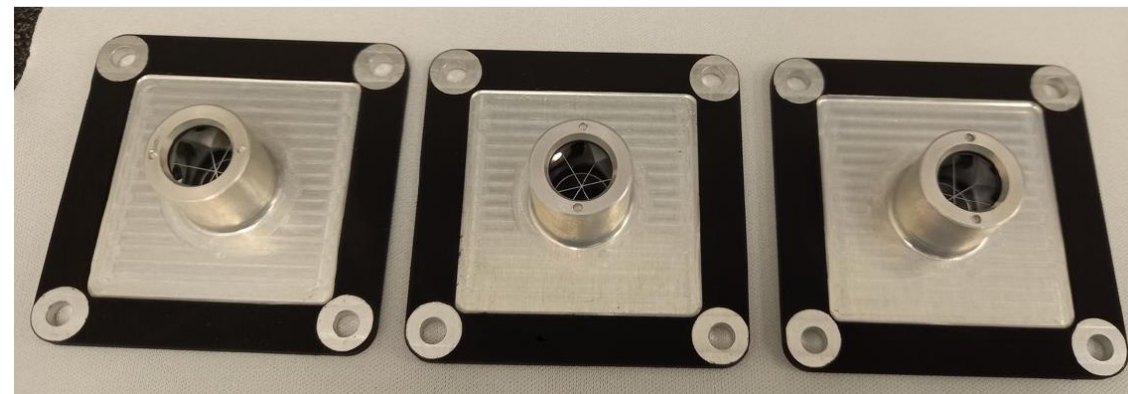
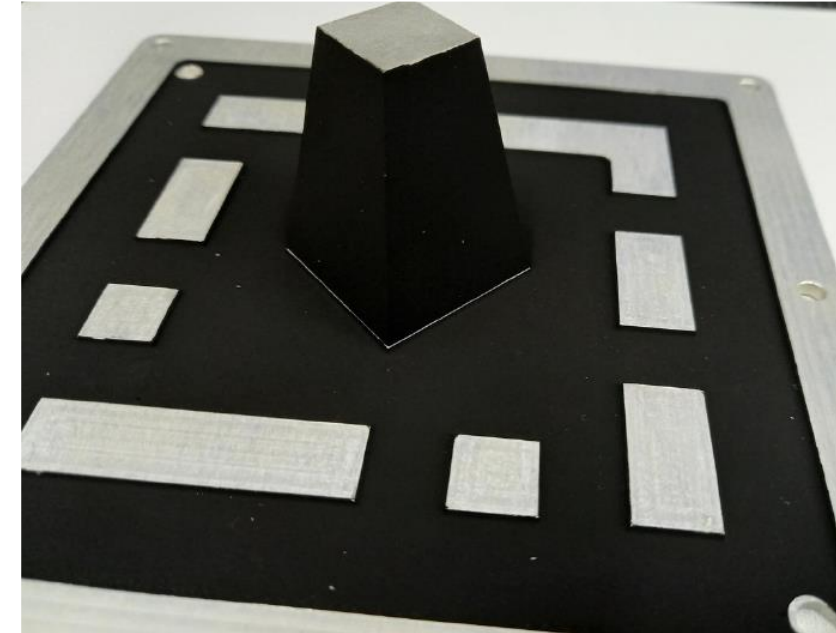

# POSITIVE – Flight hardware

- Porous Lightweight Material Development
- Part of Hungarian in Orbit (HUNOR)
- Objective is to develop technologies for building structural porous material from Moon dust in order to support colonisation. Two types of foam are under development:
  - High porosity insulation material
  - Low porosity structural material like a brick
- Experiments on ISS
- 2022 - 2025

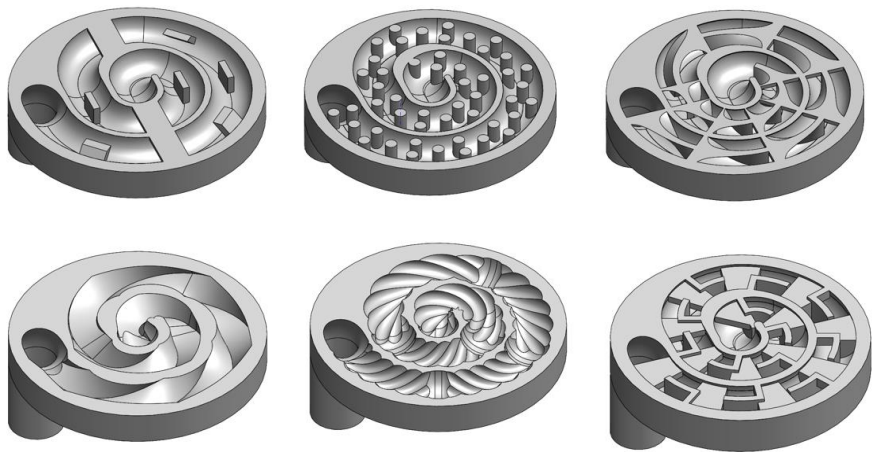

Static mixer concepts

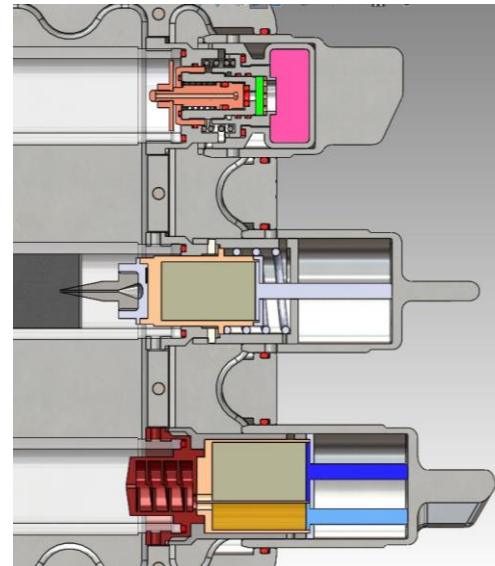

Company introduction

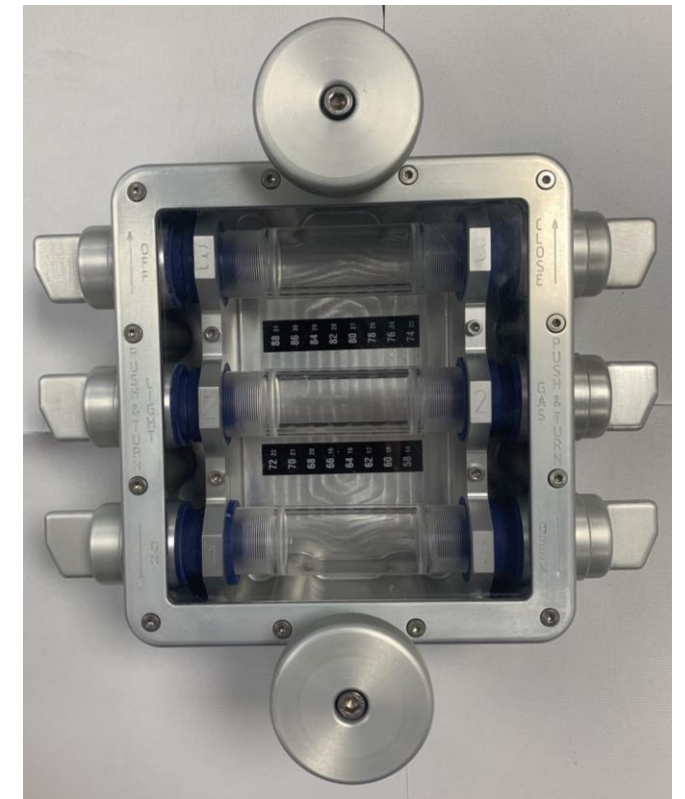

# References

## SENTINEL-2 A/B/C/D

Metallic Mechanical and Thermal Hardware are designed, manufactured, tested and delivered by ADMATIS.

Partner: [Airbus](#)

Implementation: 2009-2018

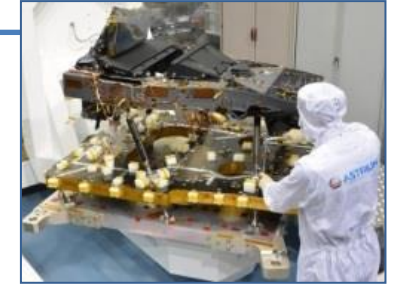
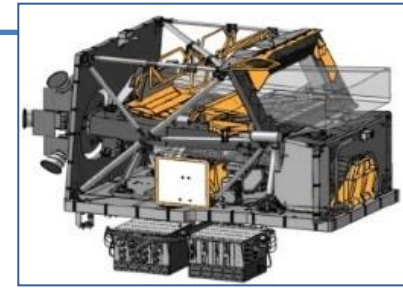
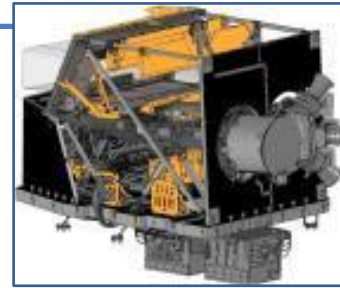

## CHEOPS

FPA and FEE radiator development to CHEOPS satellite.

Partner: [ESA](#), [University of Bern](#)

Implementation: 2013-2017

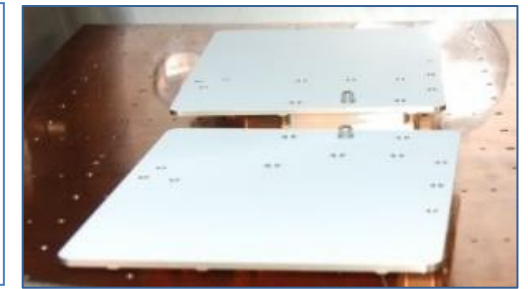
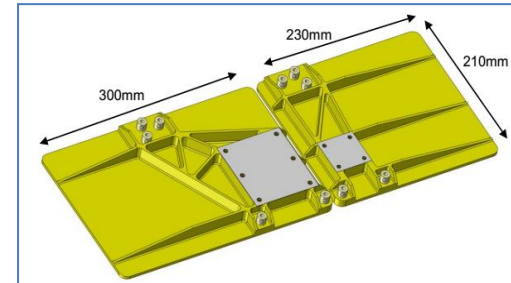

## JUICE

STM and FH MLI for PEP and Thermal dummies for SWI instrument

Partner: [ESA](#), [Airbus](#), [University of Bern](#)

Implementation: 2020

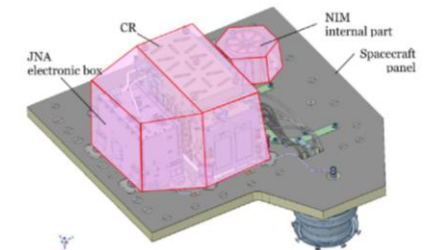
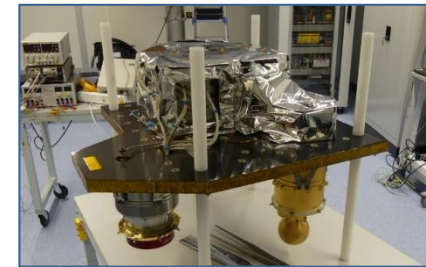

## FOCUS

Foaming experiments on board of ISS in February 2010.

Scientific background and hardware development.

Partner: [European Space Agency \(ESA\)](#)

Implementation: 2007-2010

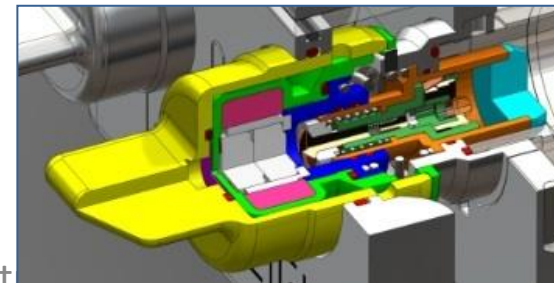

# Facilities

## Software

1. servers with Linux and Windows
2. laptops with Windows, MS Office and ESET
3. SolidWorks Premium 3D CAD
4. SolidWorks Simulation Premium
5. NASTRAN
6. Thermica
7. LabView
8. MS SharePoint
9. Microsoft Project

## Premises

1. Clean rooms for manufacturing and assembly (ISO8)
2. Clean room for cleaning and packaging (ISO8)
3. Surface treatment line and chemical laboratory
4. Conference rooms equipped with teleconf
5. Storage rooms with controlled environment

## Equipment

1. Clean Bench (ISO5)
2. Surface treatment line for SURTEC and Alodine
3. Painting booth
4. Curing booth
5. MLI assembly area
6. TVC for bake-out, thermal cycling and thermal balance tests
7. Thermal cycling
8. CMMs for 3D measurement (portable arm, bridge)
9. NSS chamber
10. Humidity chamber
11. Thermal imaging
12. Microscope
13. Analytical scale
14. CNC mill for MLI cutting

## At our partners (HUNSPACE)

1. Vibration test house (University of Dunaújváros)
2. Mechanical test house (University of Miskolc)
3. Metal machining (several)



# Contact

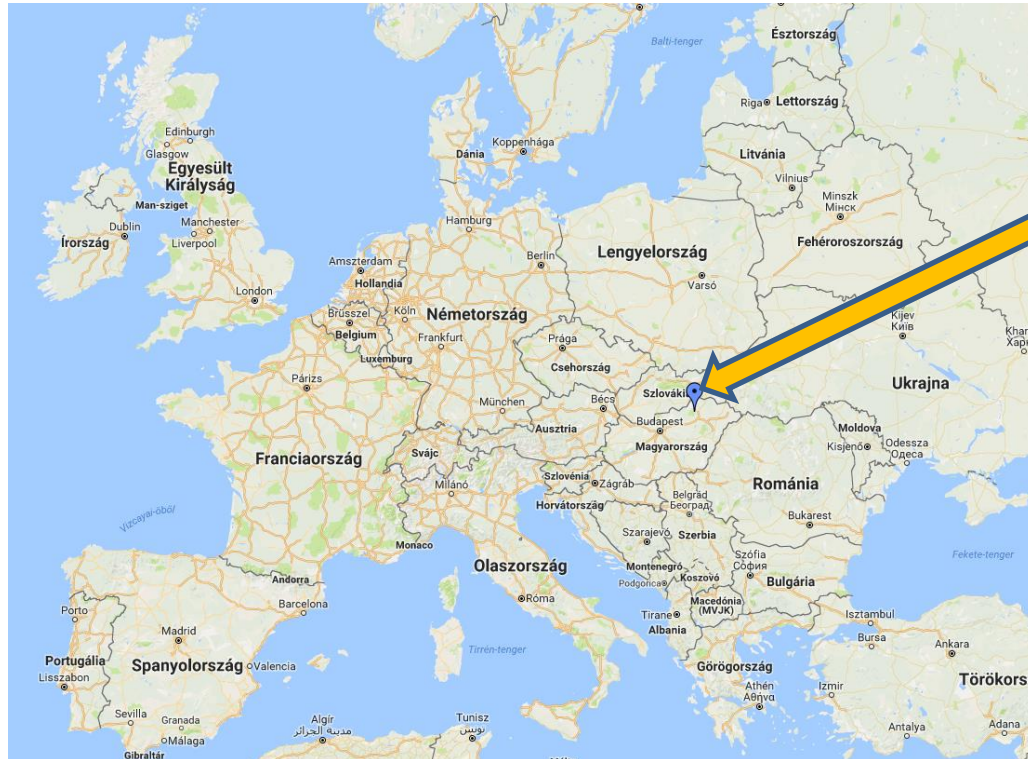

**ADMATIS**

Kando Kalman street 5.  
3534 Miskolc  
Hungary

**Tamás BÁRCZY**

CEO

[tamas.barczy@admatis.com](mailto:tamas.barczy@admatis.com)

[www.admatis.com](http://www.admatis.com)

+36 46 898-154